

AIRPLANE STABILITY, CONTROL AND TRIM

by
Robert K. Wattson, Jr. (EAA 75616)
Tri-State College
111 Summit
Angola, Ind. 46703

THIS ARTICLE IS for you if you are — itching to start on the design of your first homebuilt and have a general idea of how to go about it, but — would like to secure satisfactory handling qualities using a little more insight than ancestor worship. What we say here isn't supposed to make you a Complete Airplane Designer; a lot more than appears here is required for that. Here we will do just three things —

—First, present an engineer's view of the subject of stability, control, and trim. We'll avoid the engineering jargon where possible or if we can't avoid it we'll provide working definitions.

—Second, present in table form a series of numbers that can be used to proportion a conventional airplane. No guarantee is implied, and you'll see when you read the table that some of the numbers give you considerable room to move around. The values given are means to help you avoid serious technical surprises. If you want to be unorthodox, or if you have misgivings about what you see on the paper after you've laid on your first three-view — get help.

—Third, give a series of references using which, with assistance where necessary, you can increase your detailed understanding of what goes to make up an airplane with satisfactory handling qualities.

SOME DEFINITIONS

Although the broad subject of "flight qualities" is sometimes referred to as "stability and control", it actually has three basic divisions: **Stability** deals with the tendency of an airplane to return (or not to return) to an initial steady flight condition without pilot assistance, once it has been disturbed. **Control** deals with how the airplane responds to movements of the aerodynamic control surfaces — the elevator, aileron and rudder. **Trim** refers to whether or not, in perfectly smooth air and without any help from the pilot, the airplane will continue in level unaccelerated flight, once placed there and the controls released. It is not necessary for a trimmed airplane to be stable, but if it is stable it will "return to trim" once disturbed. If it is unstable it will "diverge from trim" in some way if it meets any disturbance.

Handling qualities is a catchall term: if the stability, control and trim characteristics of an airplane are all satisfactory, the airplane is said to have satisfactory handling qualities.

Axes: There are three reference lines, intersecting at right angles at the airplane center of gravity, to which the motions of the airplane are keyed. (Fig. 1). The airplane **itches** about its spanwise (y) axis, **rolls** about its fore-and-aft (x) axis, and **yaws** about its (z) axis. Well, almost. There is more than one definition of these axes floating around, so to avoid confusion — we hope — we'll just say that the X axis is parallel to the wind direction, and any special cases will be dealt with as they arise.

General types of stability: **static stability** exists if, when disturbed from trim, the airplane tends to return to the trim condition — without regard to how it gets

there. If there is no tendency to return to trim or to diverge further the airplane is said to be **neutral**. If when disturbed the airplane tends to diverge further from trim, it is **statically unstable**. These three forms of static behavior can be illustrated by considering, not an airplane, but just a ball, on any of three types of surface (Fig. 2).

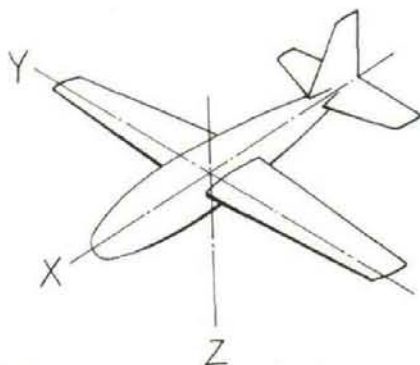

Fig. 1 — Reference axes

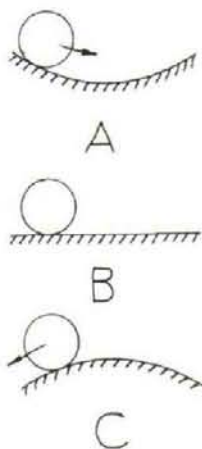

Fig. 2 — Stability: (a) positive, (b) neutral, (c) negative

This concept of static stability is fine for some purposes, but for others we need more detail, so we speak of the **dynamics** of the airplane when we want to describe just how the airplane behaves in its return to — or divergence from — trim when it is disturbed. Fig. 3 shows two kinds of dynamically stable behavior, one of neutral behavior and two of dynamically unstable behavior. Suppose that from straight and level trimmed flight at constant speed ("level, unaccelerated flight") an airplane is disturbed by a healthy pull on the stick, followed by a return of the stick to its original position. The airplane will of course pitch, and the time histories of Fig. 3 all begin at about the instant the stick is returned to its original position. The gently curved lines are a **simple convergence** toward trim and a **simple divergence** away from it. The wobbly lines are an **oscillating convergence**, an **undamped oscillation** and an **oscillating divergence**.

We speak of **longitudinal** stability about the spanwise axis, **directional** stability about the vertical axis, and **lateral** stability about the X axis, but the lateral and directional stability are hitched together — coupled — of which more later.

STATIC LONGITUDINAL STABILITY

The most convenient way to discuss static longitudinal stability seems to be to draw charts displaying "nose-up tendency" and "nose-down tendency" against airplane angle of attack, portrayed by the inclination of the **mean aerodynamic chord** — the "MAC" of the wing — to the oncoming airstream (see Fig. 4 for a simple graphical way to find the mean aerodynamic chord of a wing approximately). In the graphs that follow, airplane size and speed have been "divided out", so that all you'll see are the effects of shape and direction of the airstream.

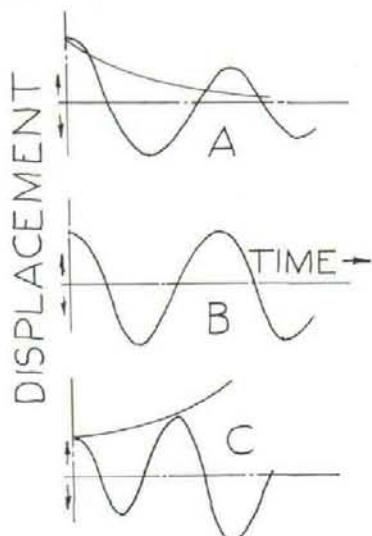

Fig. 3 — Dynamic stability (a) positive, (b) neutral, (c) negative

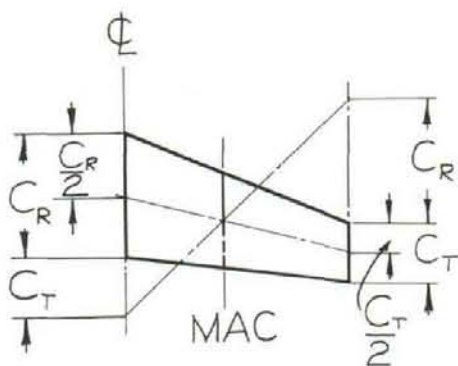

Fig. 4 — Graphical construction for approximate Mean Aerodynamic Chord (MAC)

Fig. 5 shows on such a chart an airplane consisting of only a wing, with its center of gravity at the **aerodynamic center** of the wing (a little forward or aft of the quarter chord point of the MAC — usually). This with the addition of a tiny tail is a perfectly flyable airplane, provided you agree to fly it all the time. Notice on the graph that no matter what its angle of attack it's always trying to nose down. With a piece of tin somewhere on the trailing edge, bent upward, you can persuade the beast not to nose down, or you can even select an airfoil cross-section that won't try to nose down at all. But

things won't get much pleasanter, because the airplane is neutrally stable. That is, if it gets hit by an upward gust, say, which doubles its angle of attack, it won't help you get back to your original trim angle — it will simply move upward and start slowing down until it's passed through the gust, and then if you insist on returning to the original airspeed (and angle of attack) it will hand you the whole job. Some old fighter pilots don't mind this.

Now let's add a decent-sized tail to the all-wing airplane, deflect the elevator to trim the airplane at some angle of attack "O" and pretend for the moment that the elevator is immovable — you're preventing it from moving by holding the stick firmly. See Fig. 6. The little black circle denotes the trim angle of attack. You have the stick in hand but at this angle of attack you are exerting neither forward nor back pressure.

Now "follow me through on one", as my flight instructor used to say. Pretend that the vertical gust hits the airplane and increases the angle of attack. The slanting line on the figure represents the behavior of the airplane. With the new, higher angle of attack (point A) comes a nose-down tendency, the strength of which is denoted by the distance from the angle-of-attack axis down to the slanting line. Thus the airplane now tries to correct the situation for you — noses down to get rid of the high angle of attack and go back toward the trim point. The same thing, upside down, happens when the angle of attack goes down to B, say, and the airplane tends to nose up to get rid of the deficiency and return to trim. Very nice.

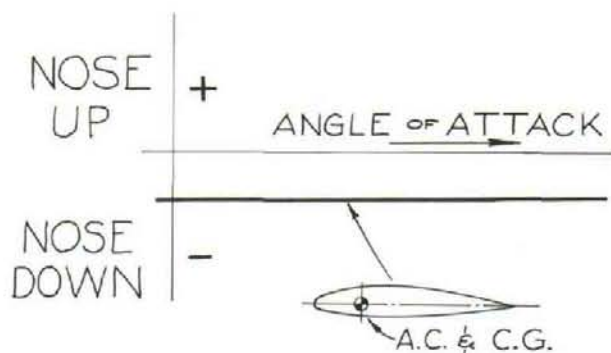

Fig. 5 — Pitching tendency of a wing alone with center of gravity at aerodynamic center.

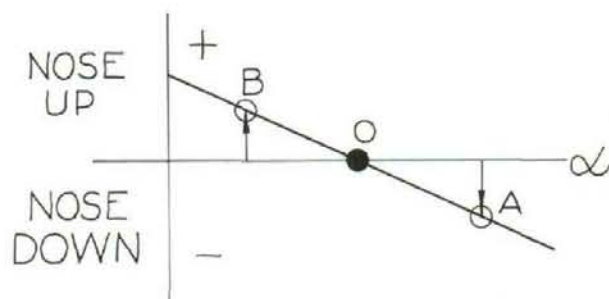

Fig. 6 — Pitching tendency of wing and adequate horizontal tail, trimmed at 0, c.g. at a.c.

The engineer's turn to confuse things comes when a fuselage is added to the wing and tail. Back in the bad old days when engines were heavy and tails were long, it used to be enough to consider that the fuselage had little effect on stability. But now engines are light and noses are long, and it appears that there is something called "lift on the body nose" which makes the fuselage destabilizing! The effect is shown in Fig. 7, which por-

trays the upward slant in our stability curve, produced by adding to the wing a fuselage but no horizontal tail. Now if the upward gust hits this combination, the effect at A is to cause the airplane to nose up, further increasing the angle of attack, which causes the airplane to try to nose up even more, and so on.

So the horizontal tail must be large enough to kill off the destabilizing effect of the fuselage, and then some. If it's not large enough to do this the airplane will be unpleasant, if not impossible, to fly — it will try to take control away from the pilot by diverging up or down from trim. An engineer is usually happy if the tail is about twice as powerful a stabilizer as the fuselage is a destabilizer. Fig. 8 presents a summary of the effects of wing, fuselage and tail that we've been talking about, and shows trends with fuselage tail or nose length and horizontal tail surface size or tail arm (distance from tail surface MAC to center of gravity).

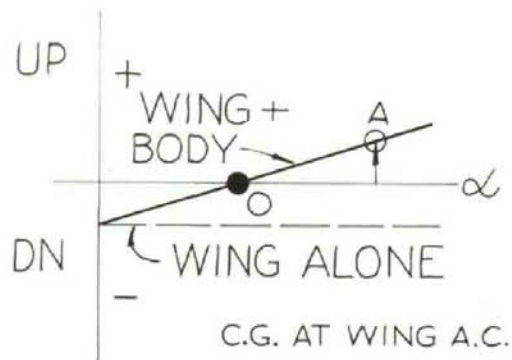

Fig. 7 — Effect of adding body

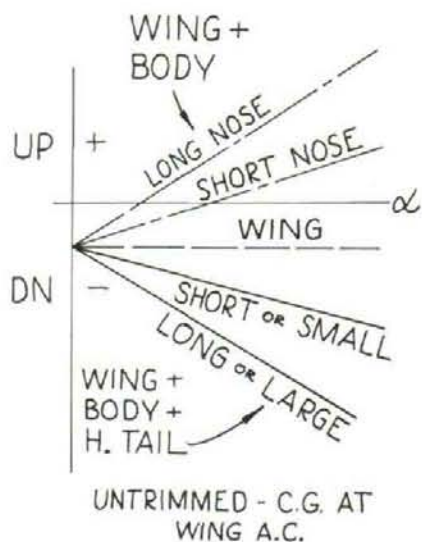

Fig. 8 — Effects of body nose length and tail length and size, c.g. at a.c.

The designer's goal is to place wing, body and horizontal tail at angles of inclination relative to each other such that at typical cruise angles of attack there is no, or very little, upward or downward force required from the horizontal tail.

Effect of Center of Gravity Location

All the above discussion was based on the statement that the airplane center of gravity was at the wing MAC. Suppose it's not; what happens now?

Fig. 9 shows the effect of forward or rearward

movement of the center of gravity. As the center of gravity is moved aft, the tendency to react correctly to angle-of-attack changes gets weaker and weaker, until finally, for some c.g. location, there is no corrective tendency at all — we're right back where we were when we had only the wing. The center of gravity is now said to be at the wing-body-tail **neutral point**, stick-fixed (remember we haven't let go of the stick; that comes later).

The wing-alone neutral point is at its aerodynamic center; this seems to say that if we get the center of gravity far enough forward we can fly an airplane with very little horizontal tail at all, but don't try it — there are other things for that tail to do, as we'll see.

Now let's move the center of gravity vertically. If it's moved down — the equivalent of changing our design to a high wing configuration — increasing angle of attack moves the resultant force on the wing farther aft on the X — axis (not on the wing chord) thus stabilizing the airplane. If it's moved up — so we have a low-wing design, essentially — as angle of attack increases the resultant force on the wing moves forward, rendering the airplane less stable. Either effect is more pronounced at high angles of attack, so the result is two curved stability lines, as shown on Fig. 10. The low-wing airplane is less stable at high angles of attack. Although if you were to make a tabulation of horizontal tail areas from commercial airplane data you'd find considerable variation, you could still discover a slight difference on the average, favoring larger tails for low wing aircraft, and this is the reason.

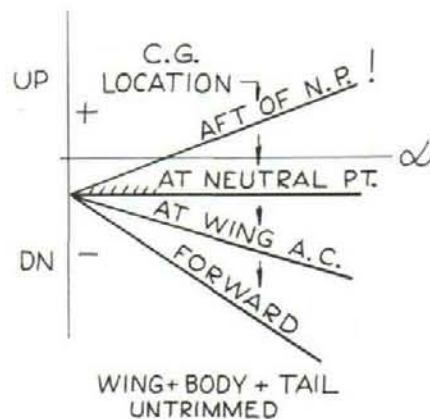

Fig. 9 — Effect of fore-and-aft movement of center of gravity

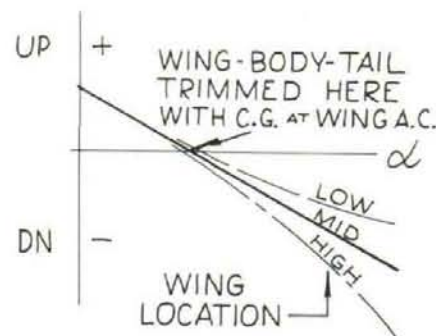

Fig. 10 — Effect of vertical movement of center of gravity

Center of Gravity Locations of Design

If for an airplane which could be loaded in a good many ways, you were to make a diagram of all possible combinations of center of gravity horizontal location and airplane weight, you'd come up with a bunch of points around which you could draw a sort of sweet-potato-

shaped line, such as is shown on Fig. 11. This is the so-called **center-of-gravity envelope**, and since the stability of an airplane depends on the location of its center of gravity, we should be concerned that it be satisfactory at every weight/c.g. combination inside the envelope. Rather than run checks of the stability at large numbers of points, we select a few of them on the boundary, at locations which experience has shown are adequate to represent the airplane. These points are usually one or two at maximum takeoff gross weight, and one or two at weights below maximum. You may hear the latter referred to as "most forward" or "forward regardless (of weight)". At these center of gravity locations certain requirements must be met, and here we must start talking about control and trim as well as stability.

At **most forward** center of gravity there must be:

—enough horizontal tail authority to rotate the airplane for takeoff (and then some); on tricycle-gear airplanes it should be possible to lift the nosewheel off the ground at speeds below stall speeds).

—enough trim capability to allow the airplane to be trimmed in landing approach (you've trimmed the airplane if you can reduce the pitch rate to zero with the stick, but on anything much larger than a J-3 it's nice to have an adjustable stabilizer to increase the total authority somewhat and to let you trim the stick force out, too).

—enough remaining elevator authority to land the airplane after changing from approach to landing configuration.

At **forward gross** the requirements are the same, and paper exercises are usually done to predict the behavior at both center of gravity locations during preliminary design.

At **aft gross** and at all other points on the aft-c.g. boundary, the important thing is stability, whereas at forward gross it was control and trim. At aft gross enough stability must remain for the airplane to behave and feel normal. A typical first-pass criterion is that the distance from the center of gravity aft to the stick-fixed neutral point must be no less than ten percent of the length of the mean-aerodynamic chord. This ten percent is referred to as "ten-percent static margin".

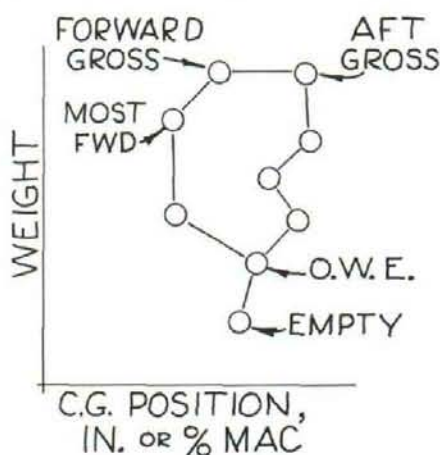

Fig. 11 — Center of gravity envelope

Stick-Free Stability

Now we have to let go of that stick and see what happens to the airplane stability, and why. In Fig. 12A is a picture of a horizontal tail in profile. We've assumed that the tail is carrying an upload, and is therefore at a positive angle of attack. The stick is "fixed" so that

there's no elevator deflection, and the airplane is being held at zero pitch rate. The tail then, is acting as though it were an unflapped wing, and its characteristics can be estimated somewhat as we should do for the wing.

When the stick is released, what happens depends on the extent to which the elevator is aerodynamically balanced — the size of the balance horn or the extent of the overhang of the leading edge, in front of the elevator hinge line. Assuming first that the hinge line is at the leading edge of the elevator (no balance), when the stick is released the elevator will float up (Fig. 12B). This decreases the up-load on the tail. The contribution of the tail to the stability of the airplane is diminished; we say its "**stick-free stability**" is less than its stick-fixed stability. Assuming the airplane is in fact stable either stick-fixed or stick-free, the curves showing the pitch-up or pitch-down tendency for the two cases would appear somewhat as shown in Fig. 12C. The stick-free neutral point — The rearmost permissible position of the c.g. without the airplane going unstable — is forward of the stick-fixed neutral point, usually about 4-7 percent of the MAC length for garden-variety airplanes.

If we want to improve this situation so we can load to more aft center of gravity locations we can add aerodynamic balance to the elevator. This causes the elevator to float up less, and restores some of the upload lost when the stick was released. It's actually possible to add so much balance that the tail will float down, thus moving the stick-free neutral point back of the stick-fixed neutral point. This is not necessarily to be desired, however.

Fig. 12 — Effect of freeing elevator on horizontal tail upload

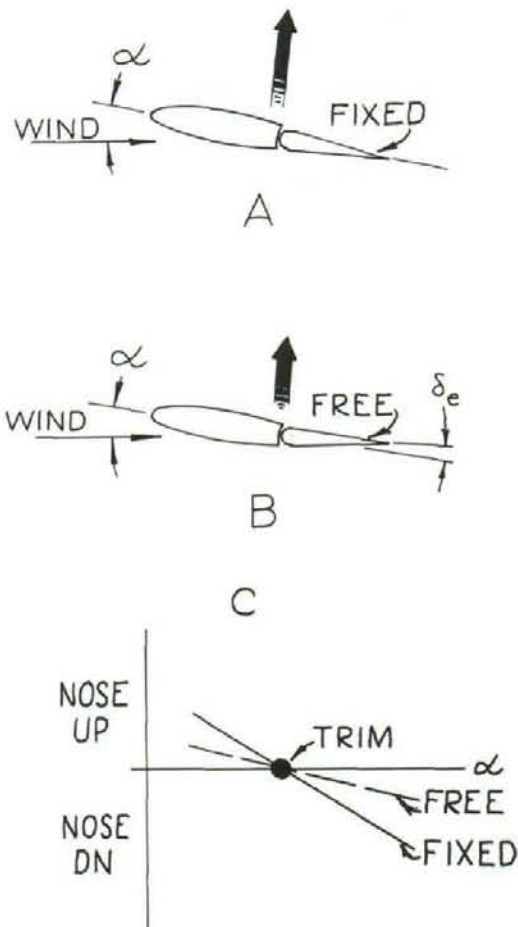

There are a couple of center-of-gravity locations behind the neutral points, which you won't have to worry about if your airplane can't be loaded back that far. If it can, you should be warned that these locations, the so-called "maneuver points", are waiting there to make your flying miserable. At one of these, the stick-fixed maneuver point, the c.g. is so located that you can put lots of g's on the airplane with hardly any control motion. At the other, the stick-free maneuver point, you can do the same thing with hardly any force. This is obviously a good way to bend the airplane.

The neutral points and the maneuver points change their location with angle of attack, so the remarks we've made about them apply only within a few knots above or below any selected trim speed. They can be found by flight test, fortunately for all engineering test pilots, by flying the airplane with the c.g. at each of several locations forward of any of them. That's another story, however.

Stick Forces

The FAA specifies, for airplanes certificated under the airworthiness requirements, that a stick pull shall be required to fly the airplane straight and level at all speeds below hands-off trim, and a push shall be required for all speeds above trim, up to and down to certain limits. Also, with the airplane held at a speed above or below trim speed, when the stick is released it must return to within a certain percentage of trim speed. This is the so-called "free-return" speed. Although not specified in the regulation, a backward motion of the stick should be required for a decrease of speed from trim, and a forward motion for an increase of speed. If an airplane does not meet this second criterion the FAA will cite the general provision that the "feel" of the airplane must be normal. Such requirements seem a little elementary now, but they were put there for good reason. Time was when the argument raged over whether the stick should be pushed or pulled to increase speed (and incidentally, whether the rudder should or should not be rigged like a sled). It is also possible, using great ingenuity, to design an airplane so terrible that while the stick motions are in the right direction the stick forces are not. And it has been done.

If, however, the airplane is stable stick-fixed and stick-free at any c.g. location and at any speed, the proper relationships among stick force, stick position and speed will exist. We can then draw a picture of, say, the stick force versus speed curve (Fig. 13), showing the elevator system friction band which helps determine the free-return speed. The question is now how large should the stick force gradient be (it seems to make little difference how small the motion excursions are, so long as they are there at all and in the right directions. The outer limits are set by the location of the pilot's midriff relative to the dashboard).

The usual ailment of a big airplane is that the stick force gradient is too high; that of a little airplane, that it is too low. The high gradient can be lowered using a geared tab (Fig. 14A); there are several flavors of this), power boost, fly-by-wire controls, or a servo tab (Fig. 14B) which is connected to the stick instead of the elevators. The low gradient can be increased by putting thin strips of metal (say of 0.1 inch square cross-section) across the span of the elevator of the trailing edge, by installing a trimmable centering spring, by sharpening the elevator trailing edge, or by a device known as a "downspring." The downspring is a very popular crutch, so some explanation is in order.

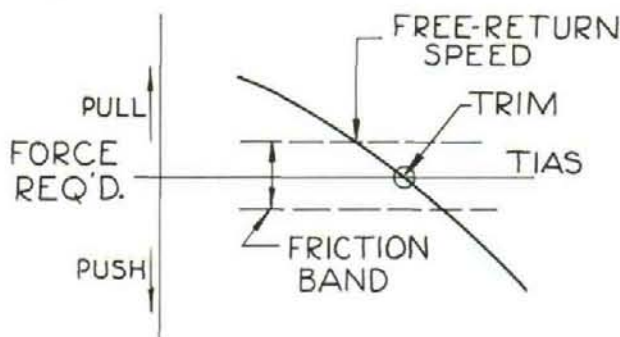

Fig. 13 — Gradient of stick force with airspeed in level unaccelerated flight.

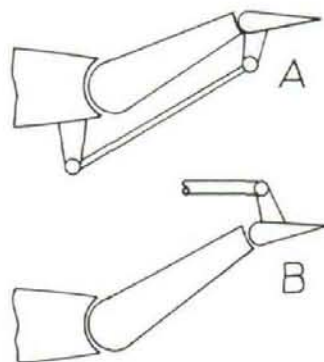

Fig. 14 — Tabs: (a) Geared, (b) servo

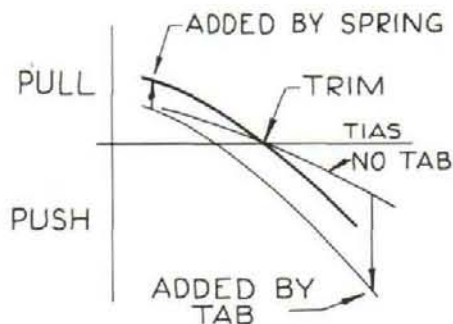

Fig. 15 — Tab and downspring effect on stick force gradient in level unaccelerated flight.

The active ingredient of the simplest form of downspring is not the spring at all, but the adjustable stabilizer or an elevator tab. The tab seems easiest to explain, so I'll use it. Suppose we have an airplane whose stick-force gradient is so shallow that too much of the aerodynamically-induced stick force is inside the friction band, and the free-return requirement can't be met. A fixed tab is installed on the elevator, and its trailing edge bent down. Now the pilot must hold the same stick positions as he did before to maintain the same speeds. But the tab is trying to raise the elevator, and the faster the airplane flies, the harder the tab tries. This means the pilot has to add, to whatever force he'd otherwise hold, a hard enough push to overcome the force transmitted to the stick by the tab. The result is shown in Fig. 15. Since the speed for hands-off trim has now been changed, this new force pattern has to be biased to raise it on the graph until the hands-off trim speed is where it was to begin with. That's what the spring is for, and you can usually tell if a modern airplane has a downspring by sampling the stick force with the airplane

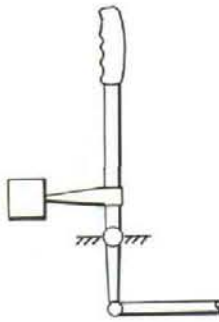

Fig. 16 — Bobweight schematic. This one requires increased pull if airplane accelerates upward (eyeballs down)

standing still on the ground. The spring can be a constant-force device (like a watch-spring) or it can be tailored using additional hardware so as to be, say, light at rearward stick positions and heavy at forward ones, or vice versa.

Another device used for the same purpose is a **bobweight** (Fig. 16). This is a hunk of metal on an arm fixed either to the stick as shown, or to some other part of the movable system where its weight will make the stick go forward. In this way it takes the place of a constant-force downspring — except that it does something else besides. Suppose an airplane so equipped and trimmed for level, unaccelerated flight hits an upward gust. The bobweight will try to stay where it is while the airplane accelerates upward. Result: the stick is pulled forward. Or suppose the airplane is in a turn; The g's you feel are felt by the bobweight too, and it compels you to haul back harder on the stick to keep the nose up. Some airplanes have to be crutched up with both downsprings and bobweights, plus/or any one or combination of other devices which the fiendishness of control system designers enables them to contrive, but which we won't describe here for fear somebody'll go try 'em on his little airplane.

LONGITUDINAL DYNAMICS

If you tried to find all the forms of dynamic stability I enumerated by flying an airplane, you wouldn't see much. There is, however, one "mode" you can develop if you have both patience and fortitude. If you trim an airplane carefully for straight level flight, then release or "freeze" the stick, a long, slow oscillation known as the "phugoid" will develop. This oscillation is essentially an energy trade between speed and height, the speed being fastest at the bottom of the oscillation and slowest at the top.

The term "phugoid" means "flying", and was hung on this particular mode before it was understood that there was another mode, the "short-period" oscillation. This "short-period" mode is very fast and very heavily damped by the horizontal tail. It takes place at essentially constant speed, and is not easily set up on a small airplane in a way you can readily see. As flight speed is decreased, the phugoid oscillation becomes faster and the short-period mode slower; for very short-takeoff airplanes the two modes approach each other in length. Heavy airplanes with relatively small horizontal tails can develop some peculiar behavior in turn entries in which short period dynamics play a part, but for small airplanes neither the short period nor the long one is much cause for concern.

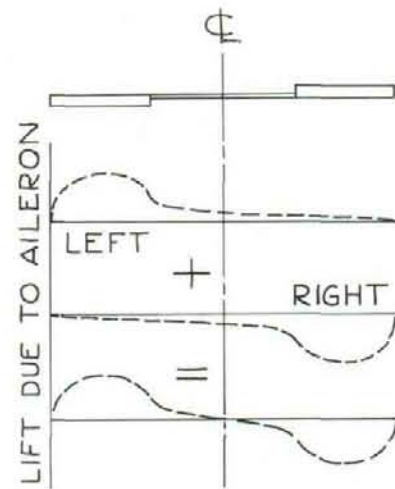

Fig. 17 — Effect of aileron deflection on wing lift

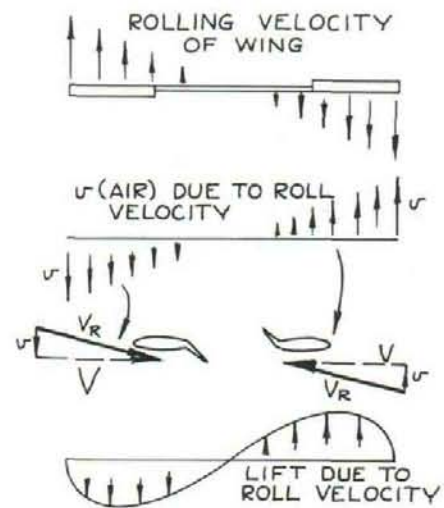

Fig. 18 — Effect of rolling velocity on wing lift

LATERAL-DIRECTIONAL STABILITY AND CONTROL

As I mentioned before, the lateral (rolling) and directional (yawing or sideslipping) stability and control modes are "coupled" for conventional airplanes. This means it isn't possible to talk about one without at some point having to drag the other in by the heels and talk about it too. We'll touch briefly on the kinds of lateral-directional stability behavior that exist, and then we'll talk about some specific items that have to do with design.

The uncontrolled lateral-directional motions of an airplane can be classified as follows:

- a **roll-subsidence** mode: this is what keeps the airplane from continuing to roll after you've cancelled out an aileron input and returned the stick to neutral.
- a poorly damped oscillation known as **dutch roll**, a combination rolling/side-slipping affair.
- a slow **spiral divergence** mode, which never causes any trouble under VFR conditions, but which used to kill people who didn't understand how it worked and under IFR conditions couldn't sort out the instrument indications quickly enough.

Roll Behavior

Whenever an airplane is upset in roll or yaw, the above three modes all begin to exercise, but how much of each one you see depends on the aerodynamics of the particular airplane you're flying. In our discussion

below we'll start simple and work up.

Let's say we are flying, trimmed in level cruise, and sharply commence a right roll, returning the stick smartly to neutral at a moment later. A number of things happen at once, but we'll look only at the wing and its ailerons and (for now) pretend that nothing happens except roll. The effect of the ailerons is to add camber on the left side of the wing and subtract it on the right. The effect of each aileron is felt by the wing from one wingtip to the other (bet you didn't know that), but the new result is additional lift over the lefthand panel, and diminished lift on the righthand one. As long as the ailerons are deflected this can be considered to be present. (Fig. 17).

But there's more. As the roll velocity builds up, the wing resists it. This is because the angle of attack on the downgoing (right) side increases while the angle of attack on the left panel decreases (Fig. 18). There is thus an addition to lift on the right panel and a decrease on the left. The faster the roll, the greater is this effect, and if we could continue the maneuver long enough, we'd finally find that we weren't building up roll rate anymore — the power of the ailerons had been caught up with by the resisting tendency of the wing. When we finally return the stick to neutral the roll stops, again due to the resisting effect of the wing. This is what is known as **roll damping**; to stability and control experts the total behavior is the roll subsidence.

The farther out on the wing the aileron is, the greater power it has, so outboard aileron ends are placed very near the wing tips. The longer the aileron is, the more powerful it is, but trying to squeeze more power out of an aileron by adding area on the inboard end is effective only to a point: the last few inches outboard of the fuselage don't buy you much. Likewise the last few inches inboard of the tip don't buy much either, so we could envision the effect of adding area somewhat as is shown in Fig. 19. In this figure the outboard end of the aileron is assumed to be at the wing tip, and the inboard end is whatever you want it. The engineers' graphs are made up a little different, but it comes to the same thing. For a conventional airplane, at the point where the ailerons extend from the tips inboard to about half the span of the panels, the relative effect of adding still more aileron span starts to fall off. By that point also, the airplane is usually pretty alert to aileron inputs, so it's a good place to stop, especially since you may want some room left for flaps. Biplanes need almost this much on both upper and lower panels.

It's fair to ask: what happens if I elect to try for greater aileron effectiveness with increased aileron chord. The reason, stated very roughly, is that what you do when you deflect ailerons is to add camber to, or subtract it from, the sections of the wing which include the ailerons, and this camber increment and decrement is what causes the unbalanced rolling tendency. Each aileron, in other words, isn't acting all by itself like a little isolated wing — it's acting to influence the lift of the entire wing, mostly that which is just in front of it. Increasing the aileron chord changes the camber for equal aileron deflections, but there's no increase of the proportion of the wing area in front of the aileron, and the relative effect of the camber change due to aileron chord change alone is less powerful.

Now how about the effects of the resisting tendency, or roll damping we mentioned a bit ago? For the sake of illustration, on an imaginary design, let's fix the aileron power (not the area, but the ability to command the initial roll acceleration, which is some different) on an imaginary design.

Now pretend that we revise the design so as to increase the span without changing the total wing area or

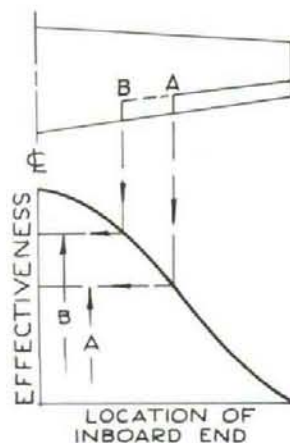

Fig. 19 — Aileron effectiveness gain due to aileron span increase

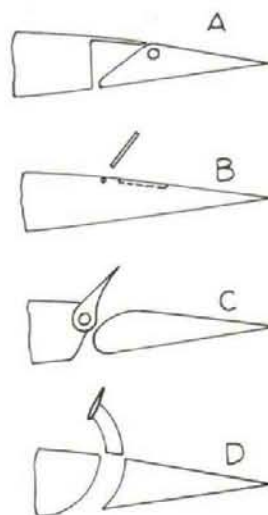

Fig. 20 — Types of lateral controls — (a) Frise aileron, (b) ventilated hinged spoiler, (c) slot-lip aileron, (d) plug aileron

the ratio of tip to root chord. This will cause the roll damping to go up. So will decreasing the taper of the wing planform. As the roll damping rises, the final steady roll rate goes down. Since the roll damping effect depends on the roll rate, the initial acceleration due to the ailerons is unchanged, but the acceleration "bleeds off" quickly. When the ailerons are neutralized the roll stops quickly, too.

Well, you say, when we increased the span we moved the ailerons out, too, so they should be more powerful. True, which is why we held the aileron **power** fixed in the paragraph above — so we could inspect what damping did by itself. As the airplane would actually be designed, the aileron power and roll damping would be "traded off" against each other, structural considerations such as wing flexibility might be rung in, and the pilot effort required to work the ailerons estimated. The result, it should be obvious, is a many-factored compromise. But since both materials and pilots are more alike than they are different, most wing/aileron designs turn out more alike than different, so a pretty good guide to proportioning is to stay within the approximate limits displayed by typical successful airplanes.

We need to diverge for just a minute to talk about a term you may hear while indulging in hangar flying — "adverse yaw." There's no certain way for you to try to experience this on a modern production airplane, be-

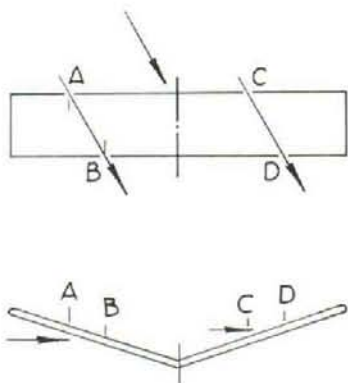

Fig. 21 — Schematic of dihedral effect

cause it's usually been carefully suppressed, but some older airplanes would behave about as follows: If you were to try to perform, say, a right roll using ailerons alone, the first thing you would notice would be a sickening **nose-left** swerve as the roll started to develop (I seem to remember being able to produce something resembling this for my stability-and-control students in their familiarization flights, and if I fudged with just a mite of top rudder I could produce a really disgusting lurch). So where did that come from? Well, when the left aileron was deflected down, it didn't produce just more lift — it produced drag too, and that's a good general fact to remember — any attempt to produce lift by deflecting the oncoming airstream induces drag too, called simply **induced drag**. On the right (up) aileron the opposite happened — less lift, hence less induced drag. So the airplane swung to the left. The way to get rid of this tendency is to fix things so the up aileron will produce some parasite drag. The Frise aileron (Fig. 20A) does this (it also does some other things). You can help with this by deflecting the up aileron more than the down one — differential ailerons. An additional benefit from this is that you "protect" the down aileron by not letting it move down so far; it doesn't retain its power up to deflections as high as the up aileron. (If it is allowed to deflect to too high an angle the result, at low airspeed, can be the opposite of what you want: the wing in front of the down aileron simply stalls, and you roll the wrong way).

Before we leave the subject of roll response we should mention the alternatives to conventional ailerons. The most important of these are spoilers (Fig. 20B, C & D). Well-designed, spoilers can be quite satisfactory. The things to remember are:

First, only one wing, not both, is effective in producing roll, so the spoiler span must be from about 1.6 to about 2.2 times the span of our conventional aileron, for equal power.

Second, the farther forward a spoiler is on the wing, the more powerful it is, but the longer it waits to become effective after you've put the stick over. On our memorable ride in a spoiler-equipped airplane we waited for what photopanel data from later flights showed was almost a second-and-a-half after full stick was in, before anything happened at all. When the roll finally got going it about tore our heads off.

Third, spoiler controls do not feel like ailerons, nor is the yaw response the same. The initial yaw is usually favorable — into the turn, not away from it — and while this sounds fine, there is such a thing as too much of it.

Successful spoiler systems have usually used a spoiler about ten percent of the local wing chord in width (fore-and-aft) positioned from about 60 to 70 percent of the wing chord aft of the leading edge. An example (patented) appears on the Mitsubishi MU-2.

The National Aeronautics and Space Administration has done some recent work with spoilers applied to light aircraft, and there is much older literature also available on many types of spoilers.

Dihedral Effect

The effect of dihedral angle can be shown using a front and a top view of oversimplified airplane (Fig. 21). The picture shows the airplane yawed to the direction of flight. Eliminating details of the flow over the wings, it can be seen that air flowing over the windward wing leaves the vicinity of the trailing edge relatively lower than it would were the airplane unyawed. Air flowing over the leeward wing leaves it relatively higher, etc. Thus the angle of attack of the windward wing has effectively been increased, and that of the leeward wing decreased. The result is that the airplane rolls away from the wind.

If you were to fly an airplane with very little vertical tail, and lots of dihedral, the result of yawing the airplane would be a roll, followed by a slip to the downwind side. The slip would change the direction of the oncoming airstream, and a roll in the opposite direction would set in. This process would repeat — nose-left yaw, left roll, left slip, right roll, right slip — until you get on the rudder and the ailerons to correct things. This is **dutch roll** (don't ask me what's Dutch about it), and it will not correct itself unless there is enough vertical fin to cause the airplane to nose into the slip.

At the other extreme, an airplane with no dihedral and a large vertical fin will respond to a slip with no correcting roll at all. The vertical tail will simply take over and turn the airplane into the slip. In the lack of anything to hold the nose up, the plane of the turn is tilted downward toward the direction of slip. The nose falls, the airspeed increases, the decreased angle of slip is offset by the airspeed increase, the airplane turns some more, the nose falls some more, and so on until you roll it out. Your flight instructor probably told you that this type of behavior is particularly deadly when you're on instruments and using only needle, ball and airspeed.

Fortunately for chronic map-gazers like myself, there is between these two extremes a stable region which can be counted on to forgive anything except the most flagrant head-down-and-locked behavior. The stable region can usually be entered, for conventional airplanes suffering from annoying dutch roll behavior, by increasing the wing dihedral. Conventional airplanes with objectionable spiral guide behavior can usually be improved by increasing the wing dihedral. The consequences of excessive dihedral shows up when steady slips must be held, as in crosswind landings. Aileron must be held in to correct the tendency of the airplane to roll away from the wind, and too much dihedral therefore limits crosswind landing capability by using up too much aileron authority. Agreeable airplanes typically have some aileron authority left at the maximum sideslip angle attainable in a straight slip, i.e. they run out of rudder first.

How much stability, how much control authority, are "enough"? It wouldn't do much good for me to quote engineers' rules of thumb or to spout strings of mathematical "derivatives" which mean nothing unless they are properly assembled. Over the years, however, general agreement has been reached on what constitutes a pleasant, docile airplane. Perhaps surprisingly, this is not the same thing as a very stable airplane, for reasons similar to those cited in the previous paragraph — too much stability uses up control authority, and usually produces a disagreeable ride anyway. The limits of propor-

tioning between which a conventional airplane can be expected to be reasonably agreeable are shown in the table at the end of this article.

CONTROL FORCES

Most of our judgments about control "feel" are formed by whether we think a) that the forces we have to exert are about what we're used to in everyday life on the ground, and b) that the motions of the cockpit controls are somehow consistent with the forces. During takeoff and landing we also insert an independent judgment of whether the motions themselves are reasonable in magnitude. Airplanes have been built whose cockpit controls would not move at all, the force on the wheels or pedals being sensed electrically and the signals used to actuate the control surfaces through "black boxes." Such airplanes were flyable, but somehow did not "feel" right (though I suppose if we'd never experienced anything else we'd think them quite good). At the other extreme would be airplanes whose control actions are all motion and no associated force whatever. Again this can be done electrically, and can even be approximated mechanically, but the result can be extremely dangerous. In such an airplane the pilot's sudden response to something startling can place enough acceleration on the airplane to fail its structure, though in normal flight the pilot may be able to school himself to keep control motions slow and small. So the control forces are there to protect us as well as provide signals we use in precise maneuvering. They may be adjusted by any of the means I mentioned previously.

The bobweight which is the longitudinal force-per-knot increaser can also be of use in raising or lowering the effort required to hold the nose into turns — the "stick-force-per-g" — provided the force-per-knot gradient remains reasonable. Airplanes certificated under FAR Part 23 must conform in several ways to prescribed limits of control force — "pilot effort" — both high and low. You've probably read Part 23 — if not, do so. The reasons for its provisions can be appreciated by anyone who's had to fly some of the cantankerous products of the first ten or fifteen years of this century.

STALLING CHARACTERISTICS

The type airplane in which I — and a lot of you — learned to fly would not allow me to continue using the ailerons in the normal manner as I decreased airspeed toward a stall. Instead, aileron inputs had to be made increasingly gingerly, and finally as the last knot or so bled off, the rudder was the means of holding the wings level. Performed at altitude, this was not dangerous once one got the hang of it, and it was even sort of smugly satisfying to see how long I could keep the poor old bird staggering around up there by walking the pedals.

New airplanes must be designed so that normal aileron control is retained up to the stall (through the pedal-walking technique is still useful). Although there is no way to be absolutely certain of this until the airplane flies, there are several things which can be done to increase the probability that normal control will exist.

The wing can be designed so as to stall first somewhere inboard of the ailerons. This can be done in any or all of three ways. First, a reasonable planform is adopted. For wings of ordinary slenderness or aspect ratio, tip-cord/root-chord ratios from about 0.6 to 1 or over will provide good protection. Highly tapered wings tend to stall first at the tips, slightly tapered wings at the root. Second, the airfoil section may be made different at root and tip. The tip section should be a higher-lift section than that at the root. Third, the wing can be

twisted so that the tip is at a smaller angle of attack (measured from free stream) than that of the root. Of the three, the last two require further discussion.

The tip airfoil section should be in the moderate-thickness, moderate-camber area. The high side of 9% and the low side of 12% thick are approximate limits: thinner airfoils will stall early, and very thick ones will stall at the trailing edge and will develop thick wakes at almost any angle of attack. Airfoil characteristics appear in many NACA/NASA reports, and collected data are given in NACA TR 824, in "Theory of Wing Sections" (same authors, — EAA stocks or can get it), and in "Airfoils," a German compilation by F. W. Riegels. Before making your selections, have someone brief you on the effects of Reynolds Number and how to figure them into your work.

There are two definitions of twist: geometric (chord line) twist and aerodynamic twist. Aerodynamic twist is what you want. It works like this: say that the root airfoil no-lift angle of attack was zero degrees, and the tip airfoil no-lift angle of attack was -2° . Then a wing with the root chord line parallel to the tip chord line would be aerodynamically twisted plus-two degrees (plus indicates in this case that the zero-lift line of the tip airfoil is nosed-up two degrees from the chord plane). To take out the aerodynamic twist, the tip would have to be rotated nose-down two degrees. Get it? If not See Fig. 22.

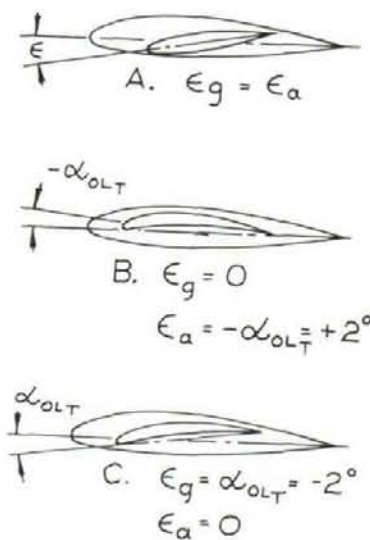

Fig. 22 — Geometric and aerodynamic twist. Subscript T refers to tip airfoil section. (A) equally cambered root and tip, (B) and (C) tip camber larger than root camber

CONTROL SURFACE DESIGN

Here I refer to the contour of the control surface, viewed in cross-section. Aileron, elevator and rudder all obey the same rules, but the tail surfaces offer more room to move around, so let's talk about them.

As we've seen, we must have tail surfaces of some sort, and their size is fixed by certain factors we can estimate fairly well. But tail surfaces add nothing to performance — they just stick out there and drag. Our only means of significantly reducing the drag is to make the surfaces thinner. Externally-braced surfaces can be as thick as their structural materials allow; internally-braced surfaces usually must be from 6 to 9 percent thick. A thicker surface generates a thick wake, with resultant poor centering.

The shape of the movable flap itself can have quite a bit to do with the surface characteristics. Control surfaces with, say true-contour 0010 airfoil sections don't always behave as they should. The peculiar behavior — typically poor centering or even porpoising of the airplane — is due to the thick boundary layers over the flap surfaces. One way to improve behavior is to select an airfoil section of higher thickness ratio than you intend for the surface. Then straighten the aft portion by drawing tangents to the basic airfoil section at the hinge line — **Fig. 23**. The outline so formed is your new airfoil section. There should be no break in the direction of the curve of the surface except that the airfoil can be squeezed a little just forward of the flap nose, not more than about 12 percent of the maximum airfoil thickness, to get some reduction in drag. Do not let the fixed surface run outside nominal contour, or the movable surface run inside it.

How about the outline or silhouette of the tail surfaces? The same aerodynamic rules apply here as do for the wing. The aspect ratio of the horizontal tail of a conventional airplane, however, should be lower than that of the wing. The lift of a low-aspect-ratio surface develops slowly as angle of attack increases, but the maximum lift is little different from that of a high aspect ratio surface. You want to retain control through a stall, and the way to do this is to assure that the wing stalls but the horizontal tail does not. The assurance is provided partly by the low tail aspect ratio.

The shape of the vertical tail should be made consistent with the appearance of the rest of the airplane, again within the aerodynamic limits. The aspect ratio can be quite low, since the presence of the fuselage and the horizontal tail effectively fool the vertical tail into thinking it is slimmer than it really is, by a factor of as much as 1.5 or so.

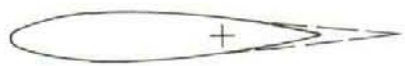

Fig. 23 — Tailoring movable tail control airfoil section

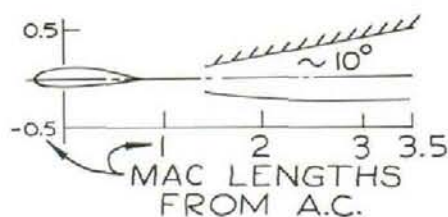

Fig. 24 — Horizontal tail location relative to wing for best stall warning and freedom from pitchup

QUIRKS AND FREAKS

The T-tail

The horizontal tail does quintuple duty: it provides stability, control and trim, helps provide stall warning, and assists in developing normal post-stall behavior. That is, it does it if it's located right. For best stall warning the horizontal tail should be in the shaded area shown on **Fig. 24**. If the tail is above this region (the boundary is actually very fuzzy) the wing wake will not approach the tail as stall is approached, and the stall buffet will be lost. There is also some danger of the airplane pitching up at the stall. As long as wings are straight and there are no jet engine nacelles on the aft

fuselage, à la DC-9, that's about all there is to the story. But high mounted tails used together with highly swept and tapered wings and aft-pod-mounted engines are something else again: in certain combinations they can lead to what's called "deep stall", a locked-in flavor that's very hard to get rid of. The best advice is to avoid this general type of configuration altogether. If you are determined to build such a bird (and somebody will try), get help from an aerodynamicist who's been there.

Canards

The VariViggen is not for everybody to try, anyway not without a Burt Rutan around to supervise the design. An acquaintance of mine tried it with no such expertise handy, against the advice of his engineer friends. The wreckage came by on a truck the day after he made his first lift-off, and he was fortunate not to be included in it.

To get an idea of why such warnings need be uttered, let's refer back to the graphs of nose-up/nose-down tendency versus angle-of-attack. You'll see that we have indicated there that the conventionally-placed horizontal tail is stabilizing. The fact that it is stabilizing is due to its location behind the airplane center of gravity. Well, a canard tail is just the opposite — it is destabilizing. So if you hung a canard tail on an otherwise-satisfactory airplane whose center-of-gravity was on, say, the stick-free neutral point, you'd suddenly have an unstable airplane.

The cure for this — in theory at least — is obvious once it's pointed out — you say "Now why didn't I think of that?" We saw that as its center of gravity moved forward, a conventional airplane became more stable. A canard airplane behaves the same way, so it boils down to just moving the center of gravity far enough forward to more-than-offset the destabilizing contributions of the fuselage and the horizontal tail. Simple, you say. Well, let's see.

In the first place, a canard airplane has, almost by definition, no "tail" — no fuselage afterbody, that is. Now a conventional fuselage afterbody is less stabilizing than its forebody is destabilizing, for equal lengths. But a canard fuselage not only lacks an afterbody — scratch one stabilizing contribution — but it also has a longer forebody — add some destabilizing effect. So, counting the destabilizing effect of the forward-mounted horizontal tail, the comparison between conventional and canard airplanes winds up like this (for the same c.g. locations in percent of MAC):

Canard airplane stability = Conventional airplane stability

- Minus** effect of fuselage afterbody
- Minus** effect of conventional tail
- Minus** effect of longer forebody
- Minus** effect of canard tail

which adds up to a pretty darned unstable airplane indeed. Put another way, the neutral points (remember them?) of the canard airplane lie much farther forward on the mean aerodynamic chord of the wing than do those of the conventional airplane. I was once associated with a program for development of a canard airplane whose normal center of gravity range turned out to be from 85 percent to 120 percent of its MAC length **forward of the leading edge** of the wing, which shows how drastic the change can be.

Stick around, there's more to come. What shall we do about stall behavior? The book says we should have adequate stall warning and should retain control through the stall, and by implication it also says the airplane should pitch. As interpreted by the good guys that means down, not up.

We saw how we could get what we wanted on a conventional airplane by proper placement of a horizontal tail of relatively low aspect ratio. Since things have gone by opposites so far, we should expect that a canard tail of relatively **high** aspect ratio should do the job. But wait — doesn't that mean the pitch-down will be caused by the stalling of the tail, not the wing? It most certainly does — do you want that? Answers from various designers are various.

Where do we place a canard tail vertically? On a conventional airplane the horizontal tail helps in providing stall warning through its proximity to the wing wake. But the canard tail flies in the crossflow field of the fuselage forebody, which usually doesn't want to stall at all. So shall we put the wing in the canard tail's wake and hope the wing will give us at least a little something? Well, inboard of the vortexes shed by the tail, the airflow is deflected down when the tail lifts up (which uplift is one reason people get trapped into designing canards). But outboard of these vortexes the flow is deflected **up** — not so much up, but up, anyway. This means the angle of attack of those portions of the wing that are in that upflow will be increased, possibly beyond that for stall. How much? It varies with what the pilot is doing with the elevator at the time. I'm fairly certain that, what with everything else that can beat up the load distribution on the wing — props, the fuselage, maybe even nacelles — I don't fancy the idea of introducing a wing stall that will vary with a load on the tail. So the logical location of the canard tail is **above** the chord plane of the wing. Considering the available locations for the tail, this usually means it's easier to design a low-wing canard than one with a high wing.

Through yet? Nope; we haven't talked about the vertical tail, which doesn't have any structure to sit on where it's normally used to being. Instead, it sits very close to the wing, or on the wingtips, so despite the relatively far forward center-of-gravity location, square foot for square foot the vertical tail of the canard is a relative weakie. This is why the vertical tails of well configured canards vary in area from merely huge to simply tremendous.

I guess what it all boils down to can be summarized by repeating what Prof. Otto Koppen used to tell his classes at MIT: "It is **reasonable** for airplanes — like Bo-peep's sheep — to carry their tails behind them."

Flying Wings

A flying wing has no tail at all, in the conventional sense, but it still obeys the same aerodynamic ground rules we've observed til now. Its longitudinal stability must be supplied by the wing characteristics and the center-of-gravity location. What "tail" it has is vestigial — the elevator alone, hitched to the trailing edge of the wing in a cutout provided for it, and frequently split so that it can be operated through a yoke mechanism so as to serve as ailerons as well — "elevons".

It is possible to make this contraption longitudinally stable. To see how to do it and still retain the normal elevator deflection range, refer to Fig. 25. This shows, in dotted lines, what happens when the center of gravity of a wing with a conventional airfoil section — say a 2412 or a Clark Y — is moved forward of its aerodynamic center to provide stability. It simply can't be trimmed anywhere in the usable range of angles of attack without a lot of elevator deflection, and this uses up total nose-up control authority.

If the wing were turned upside down, its nosing-down tendency would be changed to a nosing-up tendency, and it could be trimmed for level flight somewhere in the usable range of angles of attack by moving

the center of gravity forward of the aerodynamic center, without the necessity for a large up-elevator deflection. Trim at other angles of attack would be accomplished using elevator deflection.

Maximum lifts of upside-down wings are low. The greater the camber of the airfoil section used, the lower the maximum lift. The desired nose-up pitching tendency can fortunately be secured without throwing away much maximum lift, by starting with a conventional airfoil section with a lot of forward camber, and reflexing the after portion of the camber line. The result is shown as the solid lines in Fig. 25. A small forward movement of the center of gravity now makes the wing stable — weakly so. If you want more stability, and hence a longer usable center-of-gravity range, simply increase the reflex of the wing camber line, and move the center-of-gravity range out forward to correspond.

A conventional high-aspect-ratio wing doesn't have much room inside where you want to sit, so a low-aspect-ratio wing is very attractive for this application. Remember, though, that a stubby wing has two characteristics you don't want — a low rate of change of lift with angle of attack, and high induced drag. The low rate of lift change can give you fits when you come to locate the main gear — one or two people have been killed because they didn't know how to handle the variables involved — and the combination of that and the high drag due to lift make the airplane poor in roundout for landing. The situation can be handled, of course; if it couldn't all the high-performance fighters, which display somewhat the same characteristics, would be in trouble. Some have been, in fact.

Since by definition a flying wing has no tail, the vertical tail picture is about the same as for the canard. All you can cram on is none too much. Along with that goes a cautionary note on dihedral: keep it low. One notable very large flying wing had no geometric dihedral at all; what little effective dihedral it had comes from its moderately swept wings. The airplane flew, but because it had to be weakly stable for the reasons we've just seen, it wasn't a very "steady" platform for the job it had to do, and for this and other reasons it was never produced in quantity.

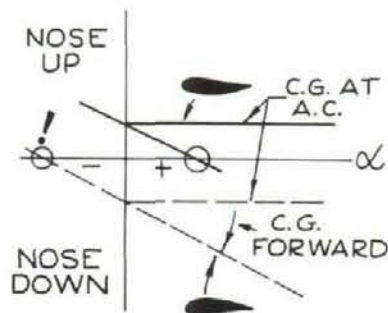

Fig. 25 — Effect of wing camber on ability to trim a flying wing with little elevator deflection

Swept-Wing Airplanes

There's no particular reason to build a slow swept-wing airplane outside of just showing you can do it. Actually, low sweep angles — perhaps 5 to 10 degrees measured at the half-chord line — won't bother you with odd characteristics. Several airplanes have had a little sweep designed into their wings to compensate for rather far-aft center-of-gravity ranges.

Beyond such small sweep angles though, things begin to happen:

—maximum lift diminishes, so stalling speed increases for the same weight and wing area.

—the lift distribution shifts outboard, so that a conventionally-tapered wing with sweep tends to tip-stall. More twist is called for, plus higher-lift airfoil sections toward the wingtips.

—the effective dihedral changes with angle of attack, being large at high angles. The lateral-directional stability characteristics therefore move toward the dutch-roll region as speed decreases (airplanes with unswept wings frequently go the other way). Geometric dihedral angles are chosen as compromises between the high settings needed for cruise flight and the very low, even negative settings needed for slow flight.

—the rate of change of lift with angle of attack diminishes with increasing sweep, producing a mild version of the characteristics we talked about for the low-aspect-ratio flying wing.

There's nothing in the above that we can't handle — with expert help, that is — but until we start building high-Mach homebuilts, why bother?

BIBLIOGRAPHY

1. Fink, R.D. et al, "USAF Stability and Control Data", Flight Control Division, Air Force Flight Dynamics Laboratory, Wright-Patterson Air Force Base, Ohio, Oct. 1960, with revisions
2. ————MIL-F-8785B (ASG) "Flying Qualities of Piloted Airplanes", prepared by USAF, 7 August 1969
3. Perkins, Courtland D., and Robert E. Hage, "Airplane Performance Stability and Control", New York, John Wiley and Sons, 1949
4. Etkin, Bernard, "Dynamics of Flight", New York, John Wiley and Sons, 1959
5. Gilruth, R. R., "Requirements for Satisfactory Flying Qualities of Airplanes", NACA TR 755, 1943
6. Phillips, W. H., "Appreciation and Prediction of Flying Qualities", NACA TR 927, 1949
7. Spreeman, K. B., "Design Guide for Pitchup Evaluation and Investigation at High Speeds of Possible Limitations due to Wing Aspect Ratio Variations", NASA TM X-26, 1959
8. Neihouse, A. T., J. H. Lichtenstein, and P. W. Pepon, "Tail Design for Satisfactory Spin Recovery", NACA TN 1045, 1946
9. Bowman, J. S. Jr., "Summary of Spin Technology as Related to Light General-Aviation Airplanes", NASA TN D-6575, 1971
10. Murray, H. E., and E. G. Wells, "Wind Tunnel Investigation of the Effects of Wing-tip Fuel Tanks on Characteristics of Unswept Wings", NACA TN 1317, 1947
11. Smetana, Frederick O., Delbert C. Summey, and W. Donald Johnson, "Riding and Handling Qualities of Light Aircraft — a Review and Analysis", NASA CR-1975, March 1972
12. Cooper, George E., "Understanding and Interpreting Pilot Opinion", Aeronautical Engineering Review", Vol. 16, No. 3, Mar. 1957, pp. 47-52
13. Abbott, Ira H., and A. E. von Doenhoff, "Theory of Wing Sections", Dover Publications, Inc., 180 Varick St., N. Y., New York 10014

14. Roskam, Jan., "Flight Dynamics of Rigid and Elastic Airplanes", published by the author, 519 Boulder, Lawrence, Kansas 66044

NOTES: Reference 3 is the oldest listed book, and has been a standby on aerodynamicists' shelves for years. Its approach to static stability and control is classic, and it reads fairly easily, but its treatment of dynamics is becoming obsolete. In universities it is being superseded by Reference 4, a comprehensive text but with British notation, and Reference 14, which is complete and very powerful.

The best general discussion of flying qualities requirements will be found in Reference 6.

The most complete single reference for airfoil data is Reference 13.

GUIDELINES FOR PROPORTIONING CONVENTIONAL AIRPLANES

Wing

Aspect ratio = (square of span)/area	5 - 8
Taper ratio of straight-tapered wing: (chord of tip rib)/(chord of root rib)	0.5 - 1
Twist	For rectangular wing 0° usually For 0.5 taper ratio 2° - 3°
Sweep	Less than 15° at quarter chord line
Dihedral	Parasol airplane 0° High wing airplane 0 - 3° Low wing airplane 5 - 7°
Thickness ratios	Not much under 9% at tip, or much over 18% at root
Camber	(higher cambers go with thinner sections) 0 - 4%
Airfoil sections	Select so as to protect ailerons at stall. If you just must use laminar flow sections, NACA 64A, a = 0.8 are the most consistent in behavior.

Flaps

Type and chord ratio — your choice, but remember that very effective (wide-chord or Fowler) flaps may cause trim change problems. Also, wide-chord flaps eat into the available space for wing structure. Flap performance data: lots on NACA 23012 with various types and sizes of flap; less on other airfoils.

Ailerons

Span	35 - 50%
Chord (total)	Usually controlled by rear spar location

Aerodynamic balance: don't try for anything fancy without help from an experienced man

Deflections Anything above about 20° down isn't very effective, and may hurt you at high angles of attack, Up deflection may be 25° or even more.

Horizontal Tail

Length from wing quarterchord line to hinge line 2.3 - 3.1 Wing MAC lengths

Total area 20 - 24% projected wing area

"Tail Volume Coefficient"

$\frac{(\text{Tail area}) (\text{Tail length})}{(\text{Wing area}) (\text{MAC length})}$

- Airplane with adjustable stabilizer 0.5 - 0.7
- Airplane with cockpit-controllable trim tab on elevator 0.7 - 1.0

Use high values for low wing configurations and for low power loadings

Aspect ratio Lower than wing aspect ratio (except for typical Canard airplane) 3.2 - 4.5

Thickness ratio Not critical for very small airplanes. For large airplanes 6 to 9%. Do not go 12% or over.

Taper ratio 0.5 - 1

Airfoil section Keep upper and lower surfaces of elevator straight. Do not allow elevator surfaces to go under contour.

Dihedral of horizontal tail none

Sweep at hinge line of elevator none

Vertical Tail

Area (not including dorsal or ventral) 12 - 15% projected wing area

Volume Coefficient

$\frac{(\text{Tail area}) (\text{Tail length})}{(\text{Wing area}) (\text{Wing span})}$.04 - .07

Note on vertical tail volume coefficient:

Use lower values for single engine, high power loading, high wing airplanes. Use high values for low power loading and twin-engine airplanes.

Aspect ratio with low mounted horizontal tail 1.0 - 1.6
with high-mounted or T-tail 0.8 - 1.0

Thickness ratio Same remarks as for horizontal tails. T-tailed airplanes can use relatively thick (10 - 12%) sections for structural reasons

Taper ratio Same as horizontal tail if h.t. is low-mounted for T-tails 0.7 - 0.9

Special note: T-tails are troublesome: get expert help if you simply must have one.

Sweep up to about 35° at the quarter chord (**sheared** method) will gain effectiveness if the root location is fixed. Maximum tail power will not show a gain in proportion.

Center of Gravity

Fore-and-aft locations between 25 and 30% of MAC will usually be satisfactory. Check loadings which will give you most forward and most aft locations. If you must run beyond these limits, run forward rather than aft. Canards: limits are farther forward. Get help!

Homebuilders, Antiques, Custom

World's Largest Variety of Fiberglass Parts. New items are under construction all the time. Special machined parts, hardware, spruce.

Write for catalog - \$1.00

RATTRAY AIRCRAFT CO.

2357 Afton Road Beloit, Wis. 53511
(608) 362-4611



Components

MARCEL JURCA

MJ-77

(P-51 3/4 scale

Information Package)

\$5.00